

NOTES: UNLESS OTHERWISE SPECIFIED

1. SEE DRAWING NO. CB-00278 AND PROCEDURE P-1000 FOR ASSEMBLY AND TEST INSTRUCTION. PROCEDURES AND ASSEMBLY DRAWINGS ARE FOR INTERNAL USE ONLY.
2. ALL TESTING IS PERFORMED IAW BATTERY COUNCIL INTERNATIONAL STANDARDS.
3. ALL DIMENSIONS ARE INCH [MM].

| REVISIONS | | | |
|-----------|-------------------------|----------|----------|
| REV | DESCRIPTION | DATE | APPROVED |
| A | REVISED CAPACITY TABLE | 3/15/00 | JBT |
| B | METRICIZED INSERT | 12/23/00 | JBT |
| C | REMOVED SIDE HOLD-DOWNS | 7/23/01 | JBT |
| D | REDESIGNED COVER | 6/26/18 | PH |

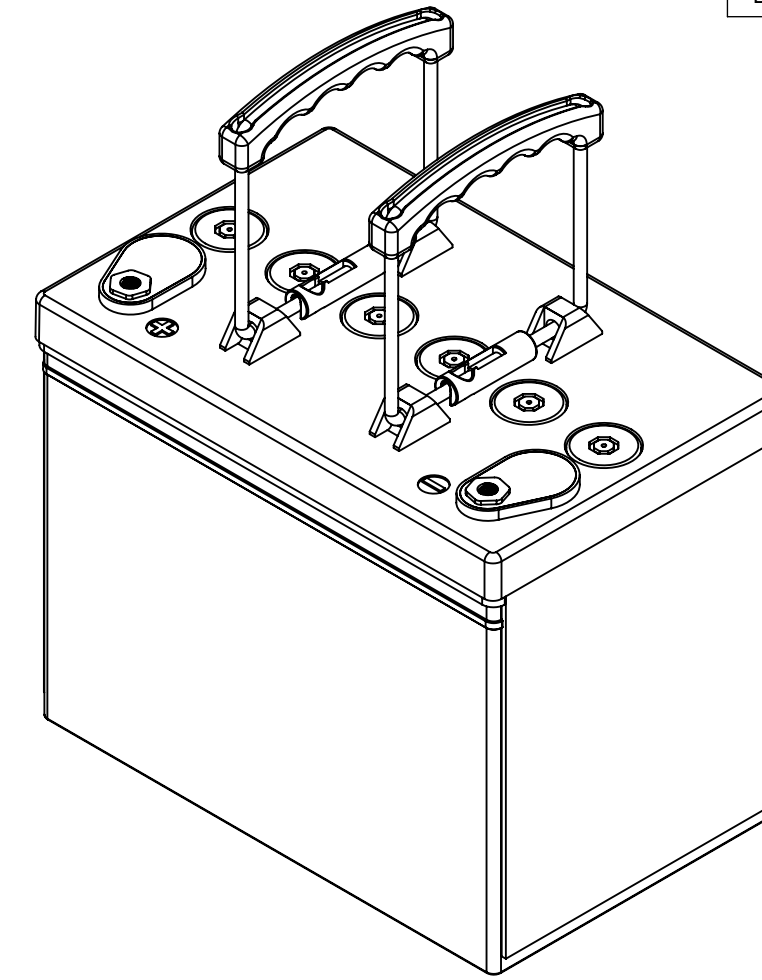
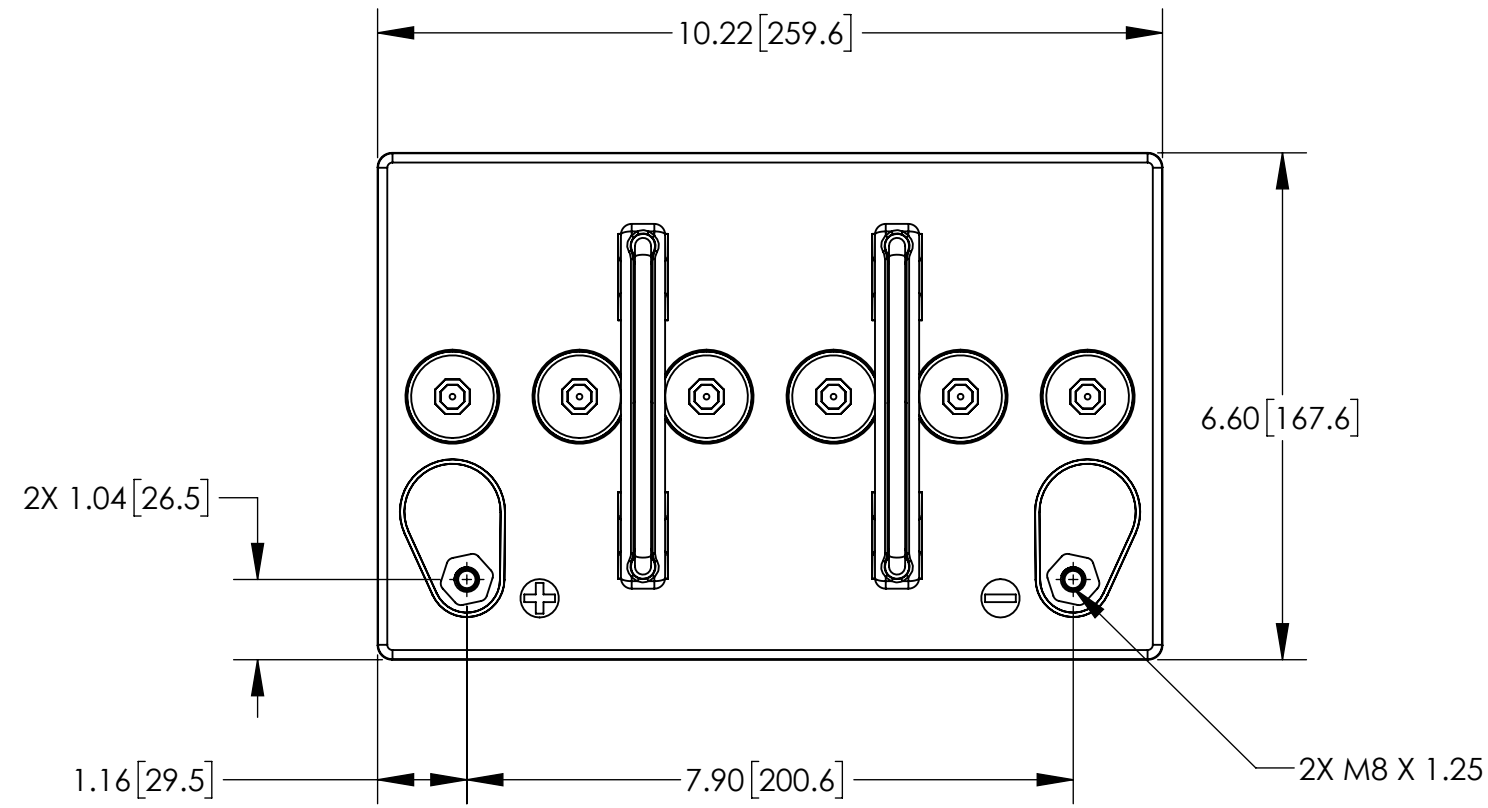

ISOMETRIC VIEW

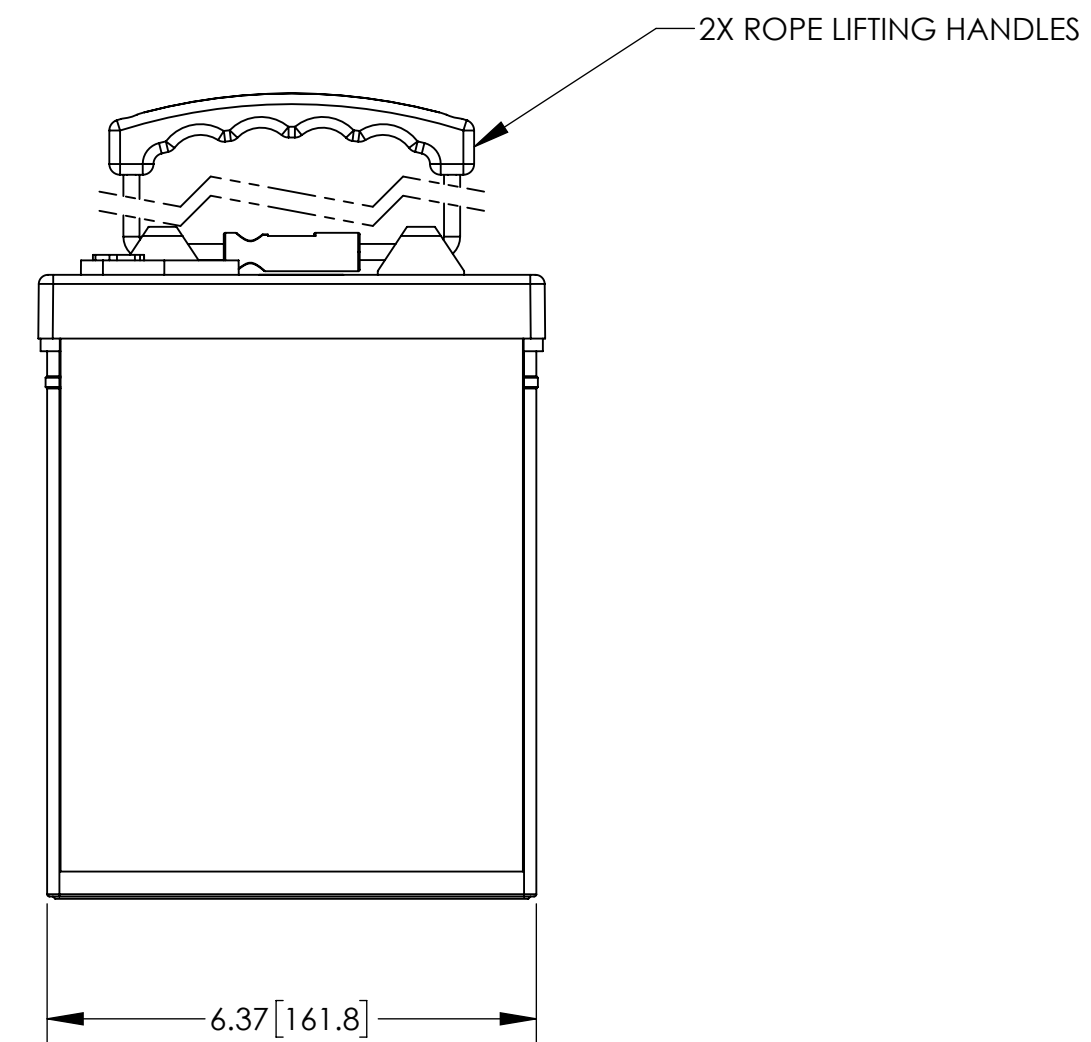
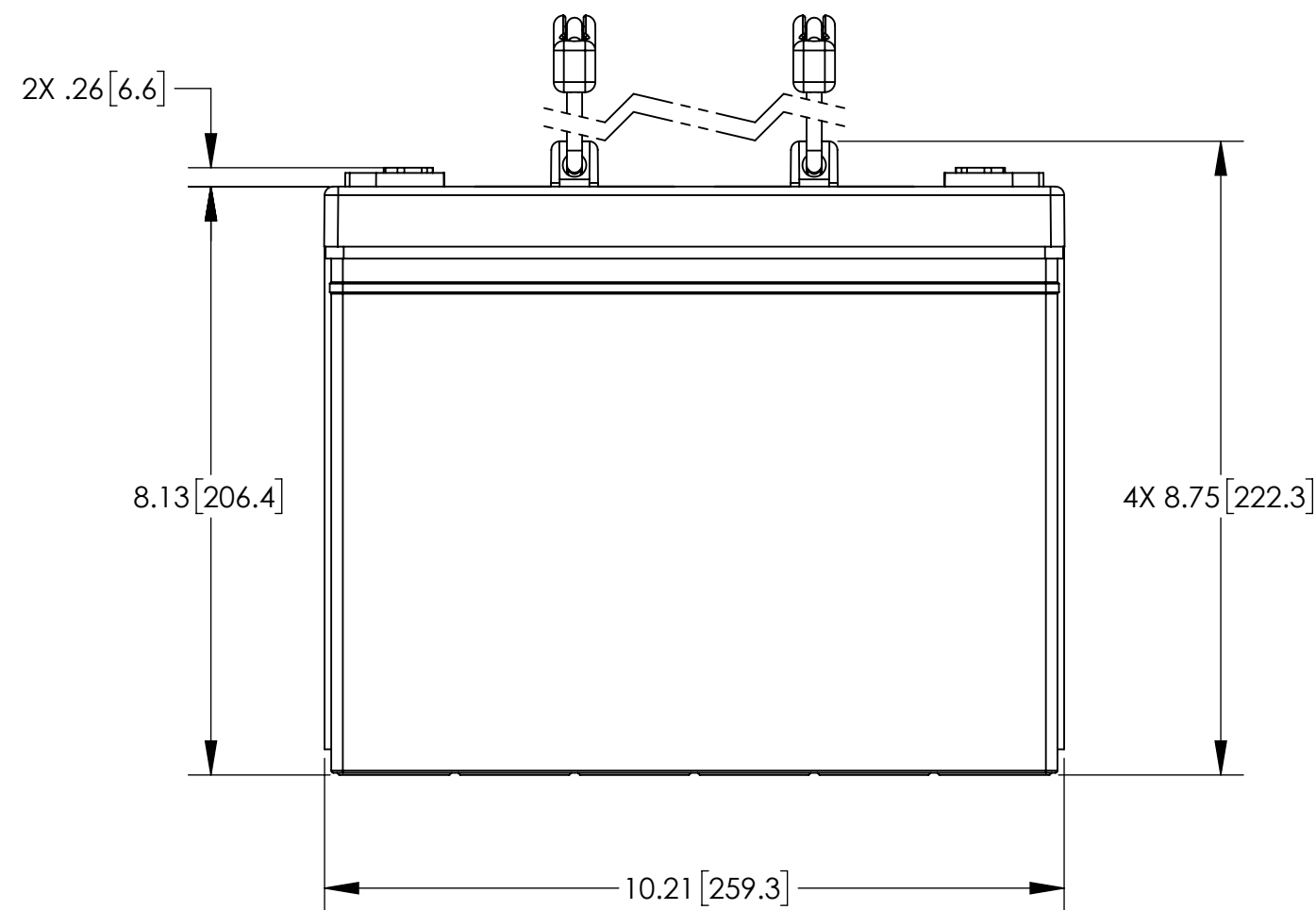

| CAPACITY RATINGS | | |
|---|------------------|------------------|
| PART NUMBER | AGM-1265T | AGM-1280T |
| NOMINAL WEIGHT | 50 LBS [22.7 KG] | 56 LBS [25.4 KG] |
| AMPERE HOUR CAPACITY @ 20 HOUR 1.75 VOLTS/CELL @ 77 °F (25 °C) | 65 AH | 80 AH |
| MINUTES OF DISCHARGE @ 25 AMPS 1.75 VOLTS/CELL @ 77 °F (25 °C) | 121 MIN | 149 MIN |

ENVELOPE DRAWING

| | | | | | | | | |
|---|--------------------------|--------|-------------------|--|---|--|---------------------------------------|-----|
| UNLESS OTHERWISE SPECIFIED DIMENSIONS ARE IN INCHES TOLERANCES ARE: | | | CONTRACT NO. | | CONCORDE BATTERY CORPORATION 2009 SAN BERNARDINO RD, W. COVINA, CA 91790 | | | |
| FRACTIONS | DECIMALS | ANGLES | APPROVALS | | DATE | | TITLE | |
| ±1/32 | .XX ± .06 .XXX ± .030 | ±1° | DRAWN ELH | | 3/01/00 | | BATTERY, 12 VOLT, AGM-1280T SERIES | |
| TREATMENT | NONE | | CHECKED S. VALDEZ | | 3/01/00 | | SIZE | REV |
| FINISH | NONE | | APPROVED JBT | | 3/04/00 | | CAGE CODE | |
| SIMILAR TO | CALC WT | | ISSUED AT | | 6/29/18 | | DWG NO. | |
| | | | | | | | AGM-1280T | D |
| | | | SCALE | | 1:2.5 | | SHEET 1 OF 1 | |