

NOTES: UNLESS OTHERWISE SPECIFIED

1. SEE DRAWING NO. CB-00279 AND PROCEDURE P-1000 FOR ASSEMBLY AND TEST INSTRUCTION. PROCEDURES AND ASSEMBLY DRAWINGS ARE FOR INTERNAL USE ONLY.
2. ALL TESTING ARE IAW BATTERY COUNCIL INTERNATIONAL STANDARDS.
3. ALL DIMENSIONS ARE IN INCHES [MM].

REVISIONS			
REV	DESCRIPTION	DATE	APPROVED

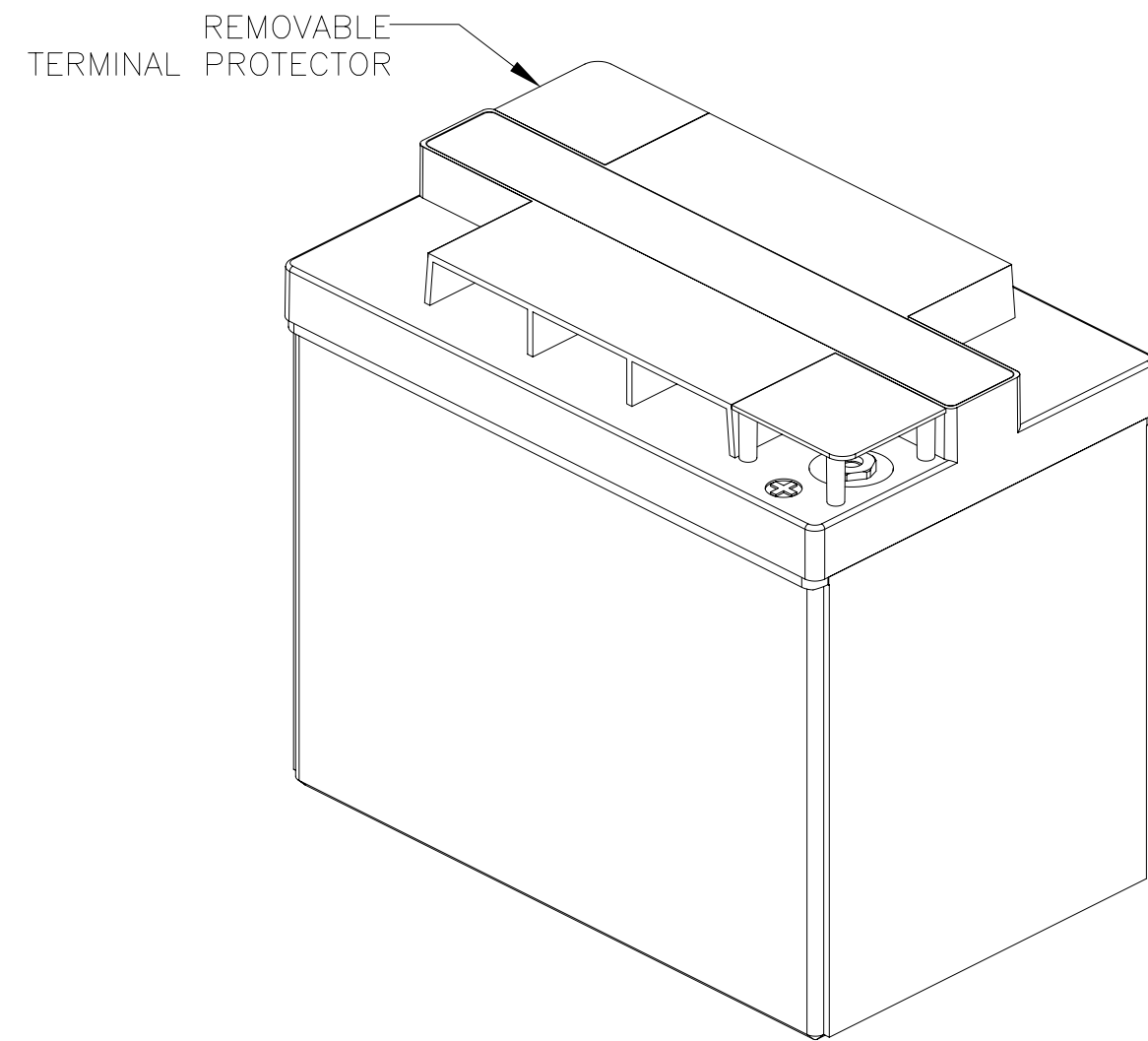
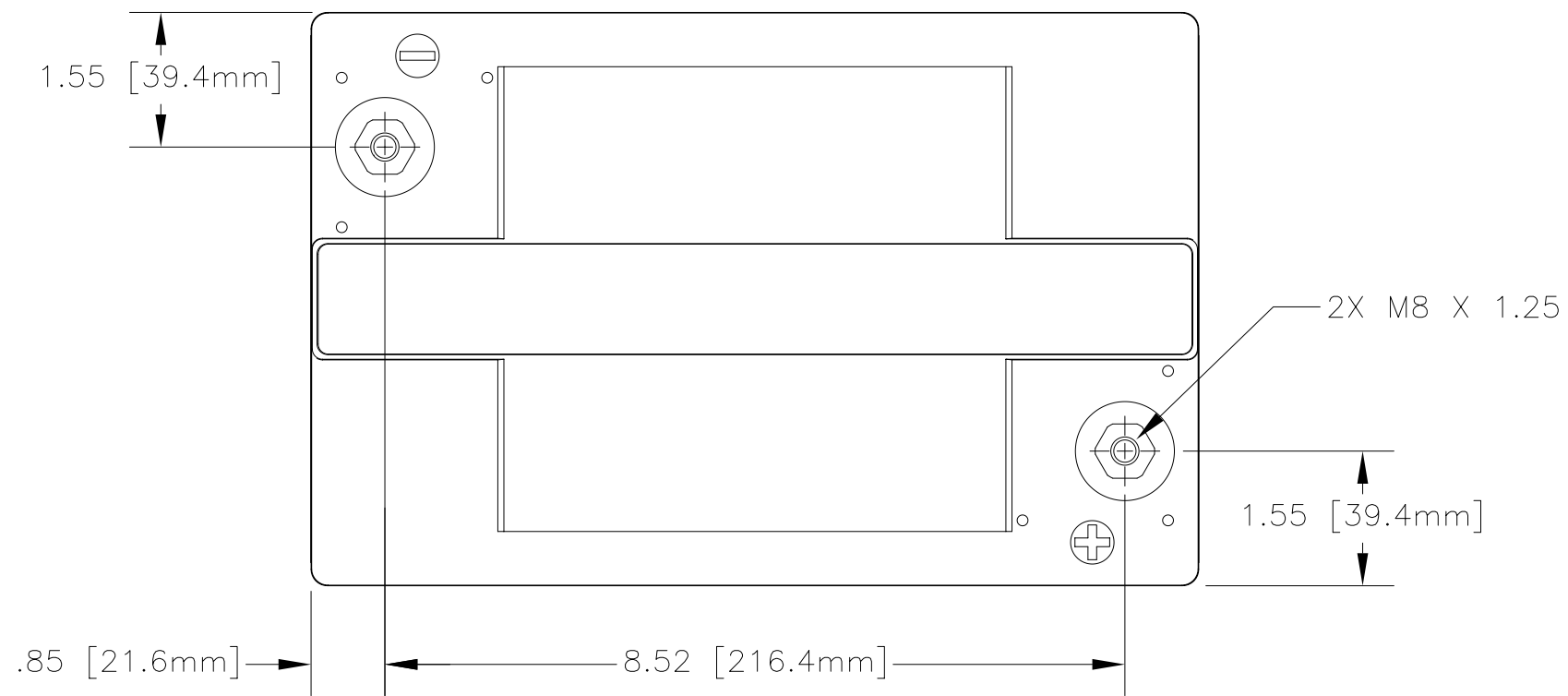

REFERENCE VIEW

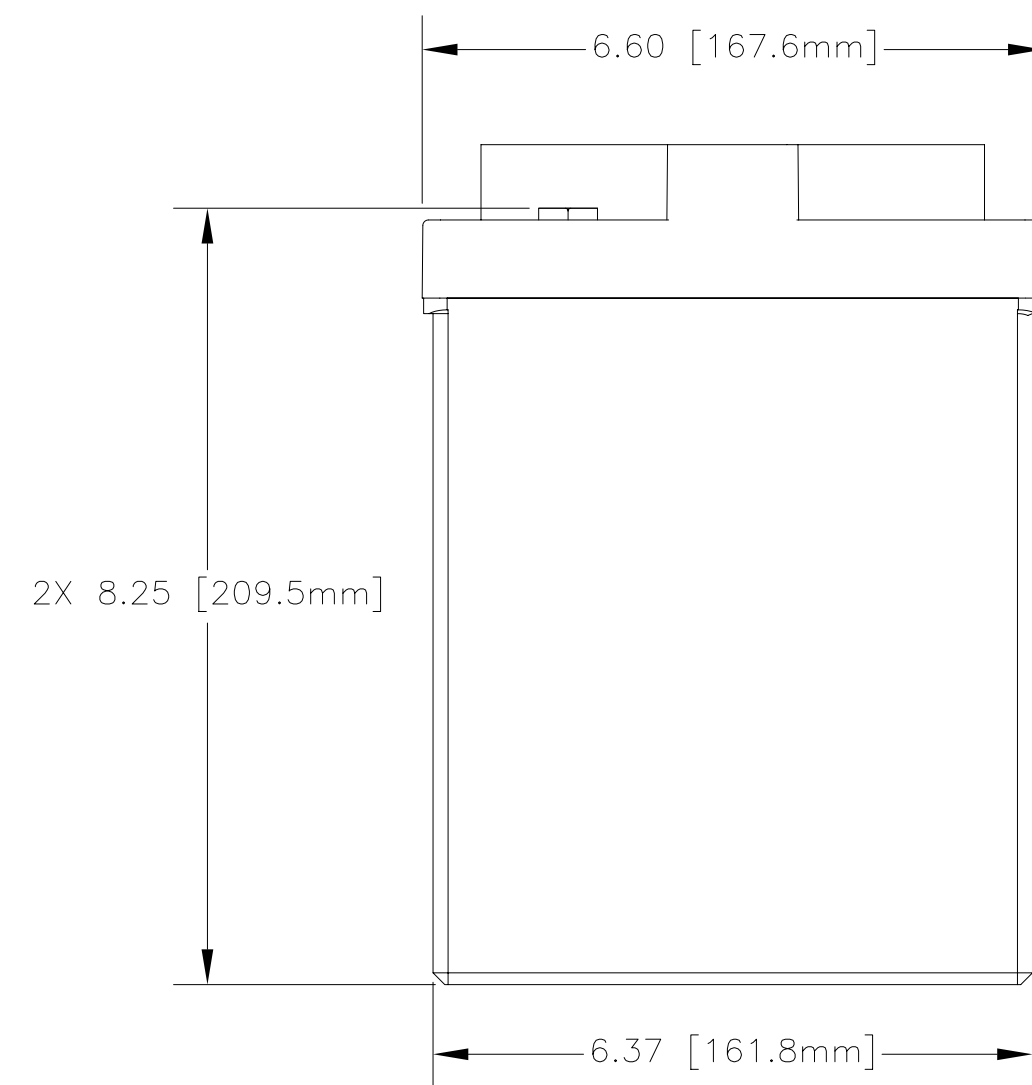
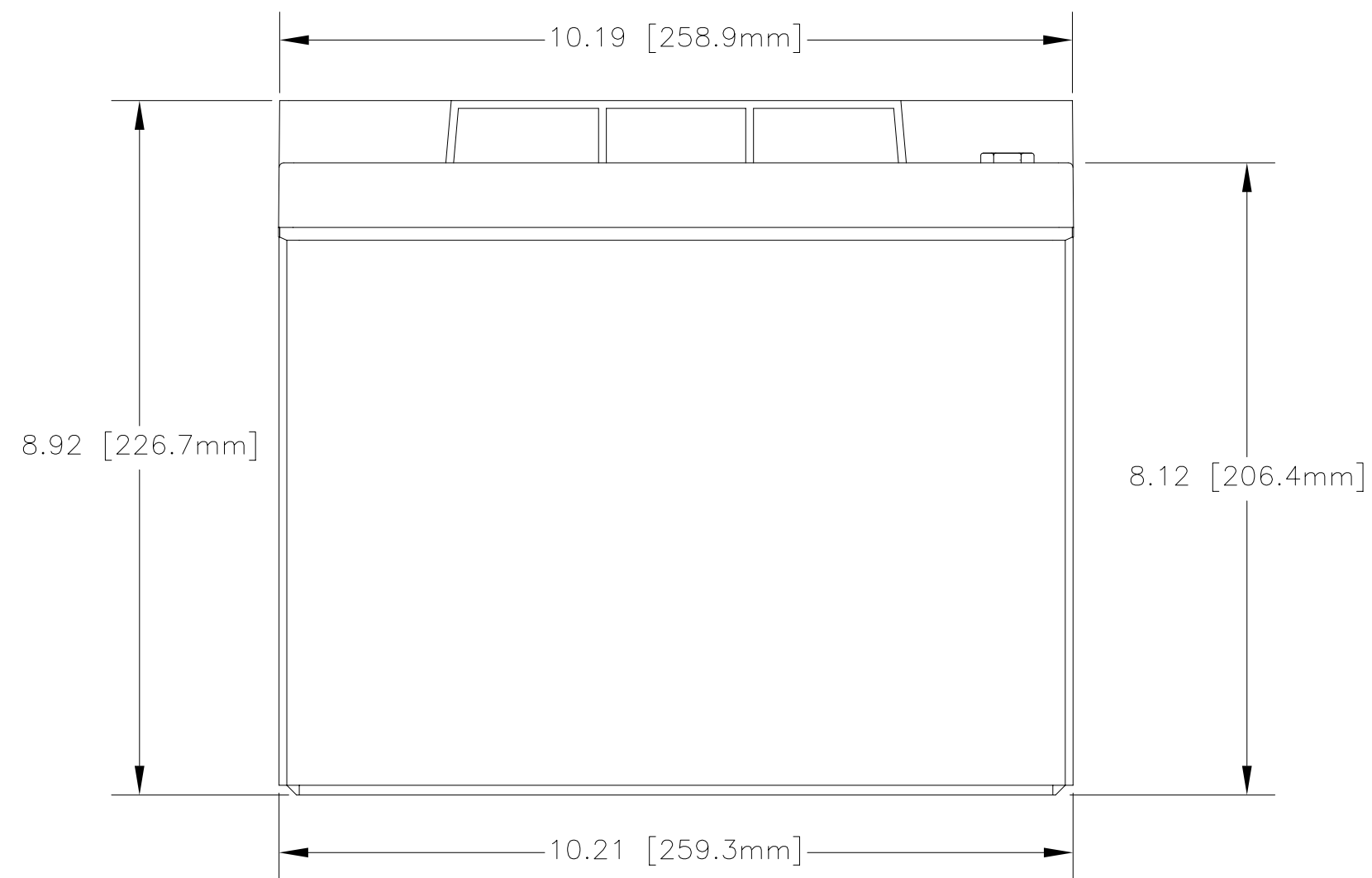

ENVELOPE DRAWING

CAPACITY RATINGS	
PART NUMBER	AGM-6100T
NOMINAL WEIGHT	42 LBS [19.1 KG]
AMPERE HOUR CAPACITY @ 20 HOUR 1.75 VOLTS/CELL @ 77°F (25°C)	100 AH
MINUTES OF DISCHARGE @ 25 AMPS 1.75 VOLTS/CELL @ 77°F (25°C)	193 MIN

QTY REQD	CAGE CODE	PART OR IDENTIFYING NO.	NOMENCLATURE OR DESCRIPTION	MATERIAL SPECIFICATION	ITEM NO.
PARTS LIST					
UNLESS OTHERWISE SPECIFIED DIMENSIONS ARE IN INCHES. TOLERANCES ARE:		CONTRACT NO.		CONCORDE BATTERY CORPORATION 2009 SAN BERNARDINO RD, W. COVINA, CA 91790	
FRACTIONS	DECIMALS	ANGLES	APPROVALS	DATE	TITLE
± 1/32	.XX ± .06	± 1°	DRAWN A. MISTRETTA	9/27/05	BATTERY, 6 VOLT, AGM-6100T
	.XXX ± .030		CHECKED AMIII	9/28/05	
TREATMENT	NONE	APPROVED	JBT	9/28/05	SIZE C CAGE CODE 63017 DWG NO. AGM-6100T REV
FINISH	NONE	ISSUED	NS	9/29/05	SCALE NONE SHEET 1 OF 1

ENGINEERING COPY 29SEP05