

NOTES: UNLESS OTHERWISE SPECIFIED

REVISIONS			
REV	DESCRIPTION	DATE	APPROVED

1. BATTERY CONFORMS TO THE PERFORMANCE REQUIREMENTS OF MIL-B-83769 AND MIL-B-83769/1.
2. SEE DRAWING NO. CB-00138 AND PROCEDURE P-1000 FOR ASSEMBLY AND TEST INSTRUCTION. PROCEDURES AND ASSEMBLY DRAWINGS ARE FOR INTERNAL USE ONLY.
3. FOR DIMENSIONS NOT SHOWN, SEE MILITARY SPECIFICATION
4. CONNECTOR CONFORMS TO MIL-B-83769 PARA 3.4.5.1.1 AND TO DIMENSIONAL REQUIREMENTS FOR MATING CONNECTOR IN IEC STANDARD 952-3 TYPE C AND BRITISH STANDARD BS 6G 205 FORM C. MATES WITH CANNON P/N 11751 OR EQUAL.
5. DIMENSIONS ARE IN INCH[MILLIMETERS].

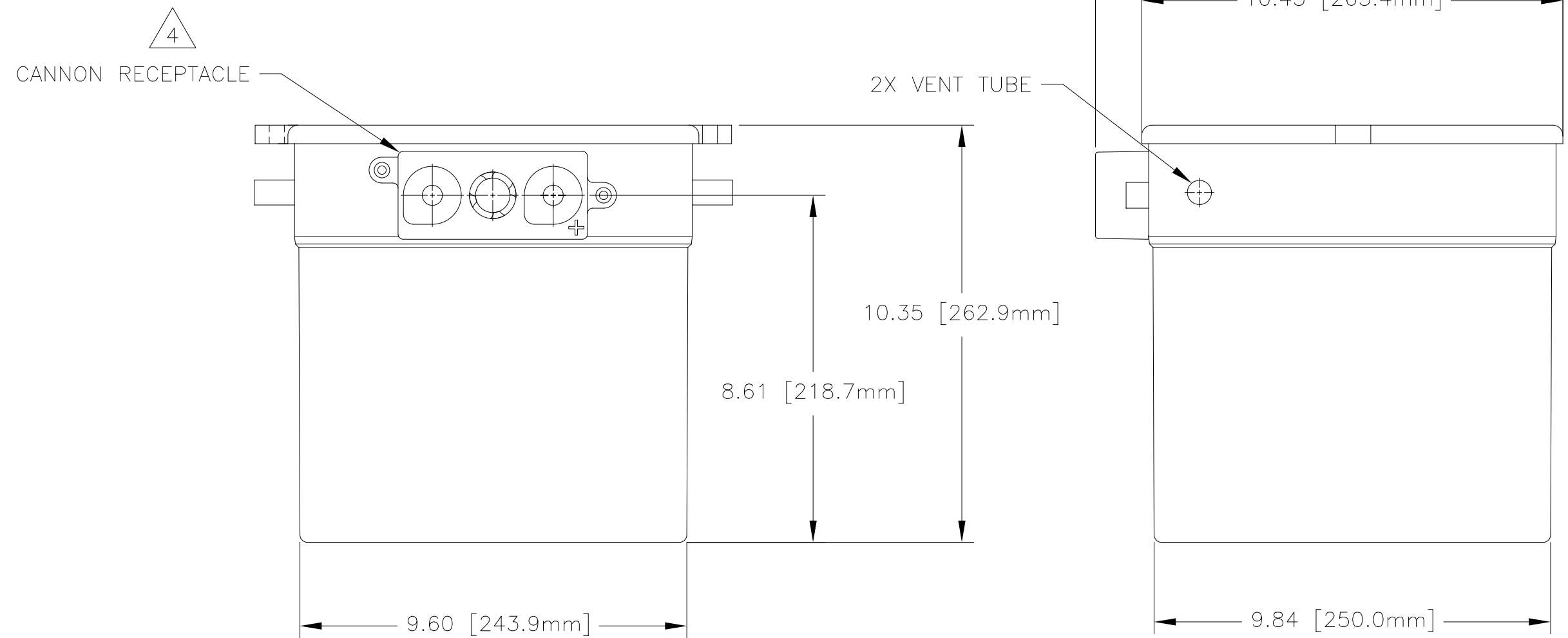
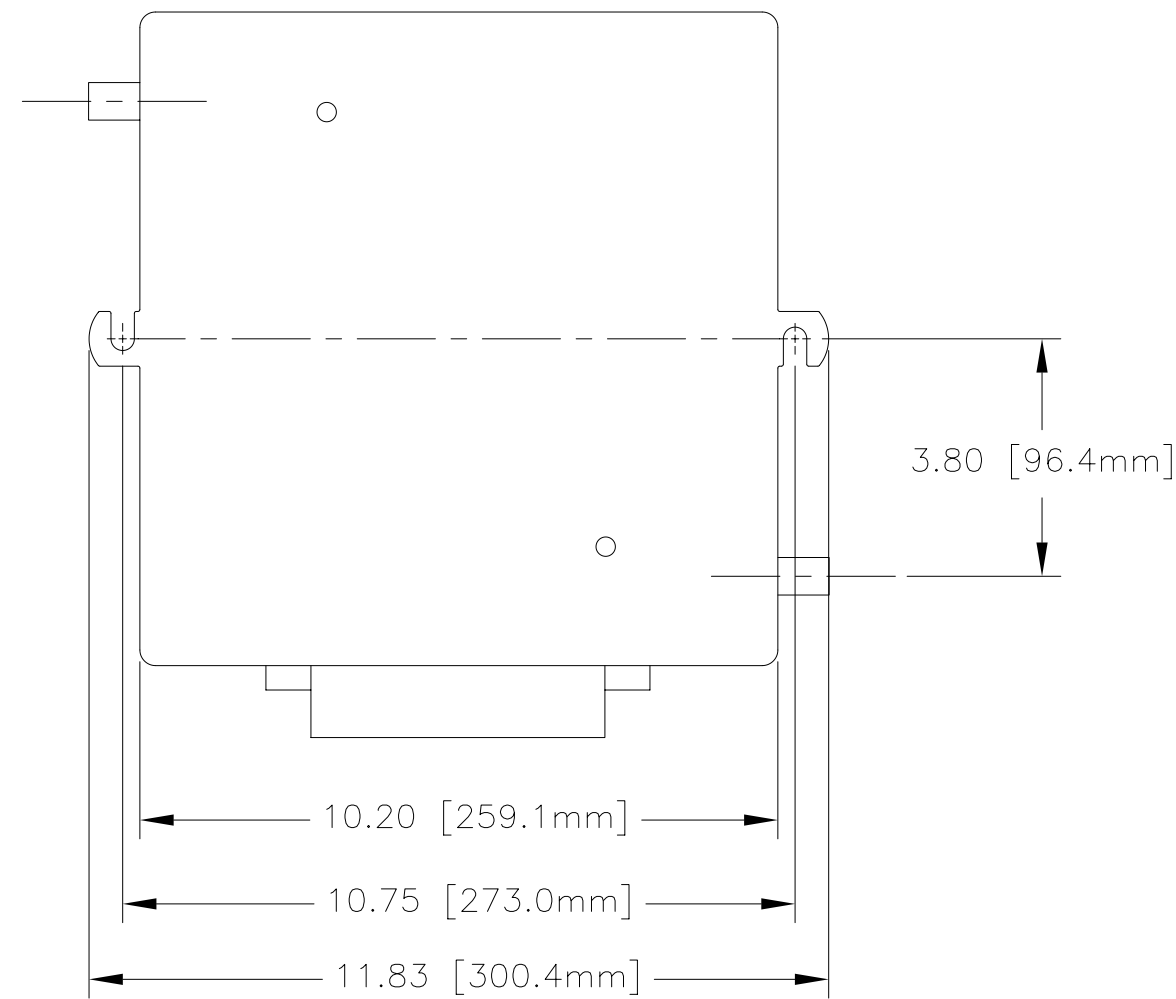

PART NUMBER	CB24-3150
MAXIMUM WEIGHT	80 LBS [36.4 KG]
1 HOUR, AMP. HRS.	31 AH
5 HOUR, AMP. HRS.	31 AH
5 MIN AMPS AT 27° C	186 A
3.3 MIN AMPS AT -18° C	186 A
2 HOUR, AMP. HRS.	31 AH
RATINGS ARE MINIMUM PERFORMANCE FOR AIRWORTHINESS IAW MIL-B-83769.	

ENVELOPE DRAWING

QTY REQD	CAGE CODE	PART OR IDENTIFYING NO.	NOMENCLATURE OR DESCRIPTION	MATERIAL SPECIFICATION	ITEM NO.
PARTS LIST					
UNLESS OTHERWISE SPECIFIED DIMENSIONS ARE IN INCHES TOLERANCES ARE:			CONCORDE BATTERY CORPORATION 2009 SAN BERNARDINO RD, W. COVINA, CA 91790		
FRACTIONS	DECIMALS	ANGLES	APPROVALS	DATE	TITLE
±	.XX ± .06	±	DRAWN JBT	12/10/02	BATTERY, STORAGE, AIRCRAFT, 24 VOLT, 31 AH
	.XXX ± .015		CHECKED AMIII	12/11/02	SIZE CAGE CODE DWG NO. REV
TREATMENT	NONE		APPROVED JBT	12/11/02	C 63017 CB24-3150
FINISH	NONE		ISSUED AT	12/12/02	SCALE 1/3 SHEET 1 OF 1
SIMILAR TO	ACT WT	CALC WT			